

# AN10991

## RM710/RM852 Hardware Design Guide

Rev. 1.1 — 6 June 2011  
191211

Application note  
COMPANY PUBLIC

### Document information

Info	Content
<b>Keywords</b>	Pegoda, RC523, RX852, LPC1768
<b>Abstract</b>	This document is outlining the hardware design details of the Pegoda boards RM710 and RM852.



**Revision history**

Rev	Date	Description
1.1	20110606	Update of <a href="#">Fig 5</a> , <a href="#">Fig 9</a> , <a href="#">Fig 12</a> , <a href="#">Fig 15</a>
1.0	20110404	First release
	20101101	Draft version

**Contact information**

For additional information, please visit: <http://www.nxp.com>

For sales office addresses, please send an email to: [salesaddresses@nxp.com](mailto:salesaddresses@nxp.com)

## 1. General information

---

### 1.1 Scope

This document describes the basic functionality and electrical specifications of the Readers RD710 and RD852.

The Readers RD710 and RD852 are designed for use in development purposes as a hardware reference design contactless reader. These readers are intended for use in connection with PC to develop application software or other hardware, based on MFRX852 or MFRC523 reader chip in connection with a Cortex M3 LPC1768  $\mu$ Controller.

### 1.2 General Description

The readers RD710 and RD852 are contactless Reader/Writer compliant to the ISO/IEC14443A standard and able to handle data rates of 106kBit, 212kBit, 424kBit and 848kBit.

The RD710 is based on NXP MFRC523 and can be operated in connection with a MIFARE SAM EV1. The SAM module can be used for key storage and enhanced crypto operation to increase the security level.

The RD852 is based on MFRX852 MiSAM X reader IC (it has a MIFARE SAM EV1 included in X-mode functionality).

Both readers use the NXP Cortex M3 LPC1768  $\mu$ Controller. MFRC523 and MFRX852 reader ICs are both highly integrated reader IC solutions for contactless communication purposes at 13.56 MHz.

The readers RD710 and RD852 are designed to work with an external [AN700 antenna](#) to achieve an optimum reading performance for contactless applications.

Both readers provide several communication interfaces on board such as: USB, RS232, RS485 (RS422), Ethernet (via LPC\_ extension board), JTAG (a JTAG IEEE 1149.1 compliant interface for debugging).

**For information on availability of samples as well as documentation, please refer to the application note 'Pegoda EV710/EV852 Documentation and Sampling guide'.**

### 1.3 Naming Convention

Name of Product	Core reader IC	Description
EV710	MFRC523	Full reference design kit, in card box
RD710	MFRC523	Full functional reader in housing
RM710	MFRC523	Reader PCB (fully functional but without cables & antenna)
LPC-COM	n/a	3 <sup>rd</sup> party extension board (extra connectors, I/O ports); <a href="http://www.nxp.com/redirect/hitex">www.nxp.com/redirect/hitex</a>
EV852	MFRX852	Full reference design kit, in card box
RD852	MFRX852	Full functional reader in housing
RM852	MFRX852	Reader PCB (fully functional but without cables & antenna)

## 2. Understanding the parts of RD710 and RD852

Just click on a hyperlink in the table below to jump to the corresponding chapter.

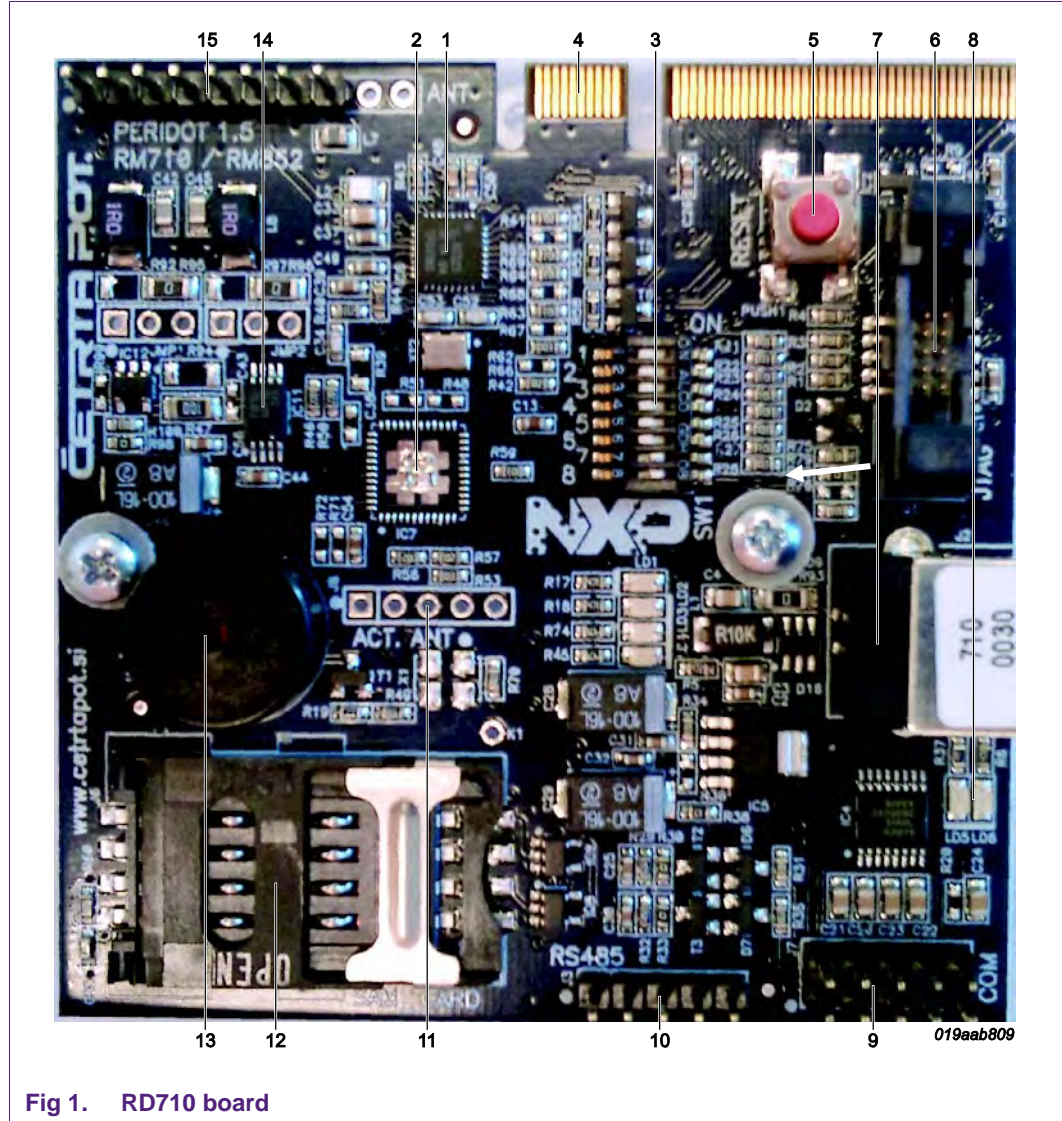

Fig 1. RD710 board

Table 1. Numbering of Figure 1

No	Description	No	Description
1	<a href="#">RC523</a>	10	<a href="#">RS485 interface</a>
2	<a href="#">RX852</a>	11	<a href="#">Active antenna interface pins</a>
3	<a href="#">DIP switches</a>	12	<a href="#">SAM slot</a>
4	<a href="#">Ethernet port</a>	13	<a href="#">Buzzer</a>
5	<a href="#">Reset button</a>	14	<a href="#">Amplifier circuit</a>
6	<a href="#">JTAG interface</a>	15	<a href="#">Antenna connector</a>
7	<a href="#">USB interface</a>		
8	<a href="#">USB activity LEDs</a>		
9	<a href="#">RS232 interface</a>		

## 2.1 RD710 Features

- contactless smart card reader
- contactless operating frequency 13.56 MHz
- data rates 106kbit/s, 212kbit/s, 424kbit/s, 848kbit/s
- supports MIFARE Dual Interface card ICs, ISO 14443A
- supports MIFARE Classic protocol
- supports MIFARE contactless cards
- supports SAM with direct connection to the microcontroller which can be configured as standard SAM and in X-mode by DIP switches and registers settings
- based on RM710 module containing the MFRC 523 reader IC and SAM card
- supports communication interfaces: USB, RS232, RS485, Ethernet (via MEC6 connector for the HITEX LPC-COM board) and included JTAG connector (for JTAG adapter)
- typical reading distance: up to 75mm
- USB host interface
- USB bus powered 5 V DC power supply
- unique serial number for each reader device

## 2.2 RD852 Features

- contactless smart card reader
- contactless operating frequency 13.56 MHz
- supports MIFARE Dual Interface card ICs and ISO 14443A
- supports MIFARE Classic protocol
- supports MIFARE contactless cards
- supports SAM in X-mode (SAM included in MFRX 852 reader IC)
- based on RM852 module containing the MFRX 852 reader IC
- supports several communication interfaces: USB, RS232, RS485, Ethernet (via MEC6 connector for the HITEX LPC-COM board) and included JTAG connector (for JTAG adapter)
- typical reading distance: up to 75 mm
- USB host interface
- USB bus powered 5 V DC power supply
- unique serial number for each reader device

### 3. RD710 / RD852 HARDWARE DESCRIPTION

Both hardware versions are described in the following chapters.

#### 3.1 Overall Hardware RD710

An architectural overview of the RD710 is shown in Fig 2.

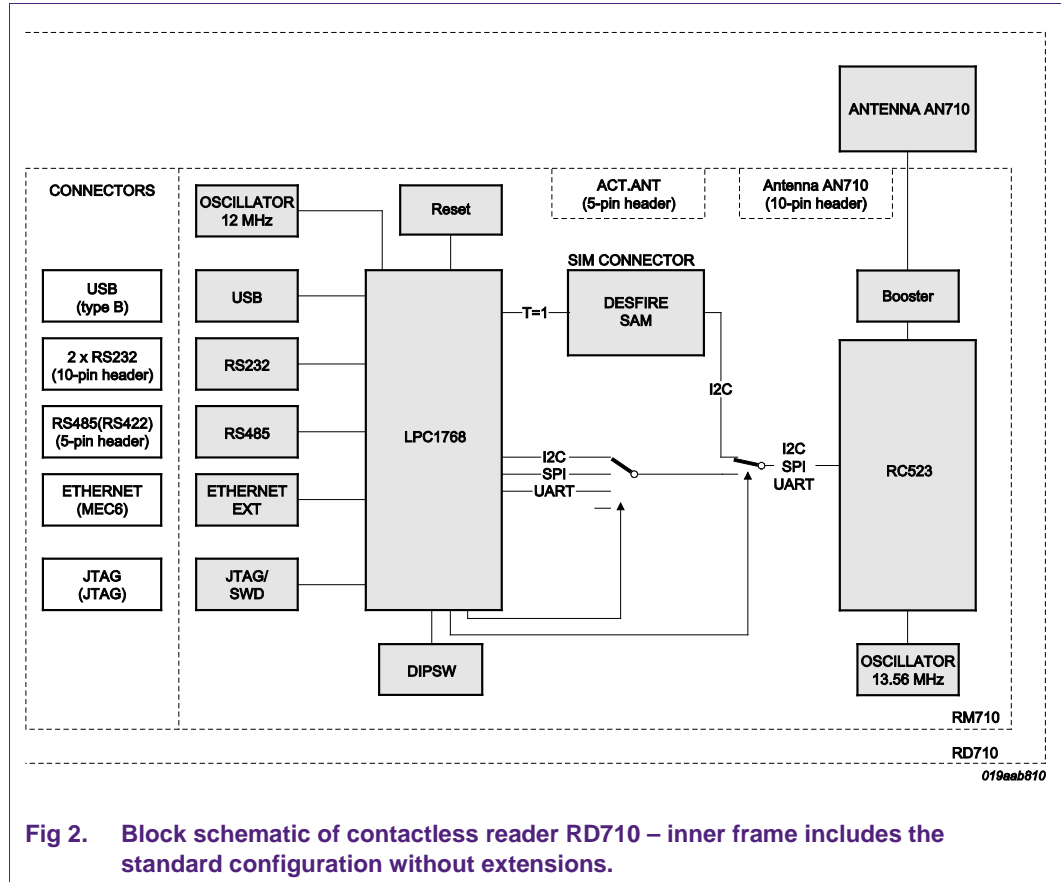

**Fig 2. Block schematic of contactless reader RD710 – inner frame includes the standard configuration without extensions.**

The microcontroller directly interfaces with its integrated peripherals to the host PC via serial port, USB or Ethernet. The serial port with RS232 compatible levels is used for downloading firmware; the JTAG port can also be used for downloading firmware and debugging. The reader IC MFRC523 is either connected via SPI, I2C and UART interface to the M3 Cortex microcontroller; this configuration is software selectable. The SAM is directly connected to the microcontroller via an ISO7816 interface with setting T=1 protocol implemented in SW on the  $\mu$ C.

An additional amplifier enhances the RF output power to achieve high field strengths. The amplifier is supplied by 5 Volts via USB bus power; the MFRC523/MFRX852 itself is only capable of handling a 3.3 Volts supply which is directly generated onboard from 5 Volts USB bus power.

The RD710 reader is designed to use existing Pegoda RD701 housing with the AN710 Pegoda antenna. The AN710 antenna is connected via a 10-pin header to the RM710 board.



3.1.1 Plugging SAM RD710

The RD710 is able to work with a SAM in a PCM module (SIM card shape) for data encryption/decryption and key storage. Therefore a SIM socket is assembled on the PCB. This socket is accessible by opening the reader housing. The SAM can be used in S- and X- configuration as shown in fig.1. The change from S- to X-configuration is done via DIP switches.

3.1.2 Reader IC RD710

The RD710 contact less reader is equipped with a NXP IC MFRC523.

3.2 Overall Hardware RD852

An architectural block diagram of the RD852 is given in Fig 3.

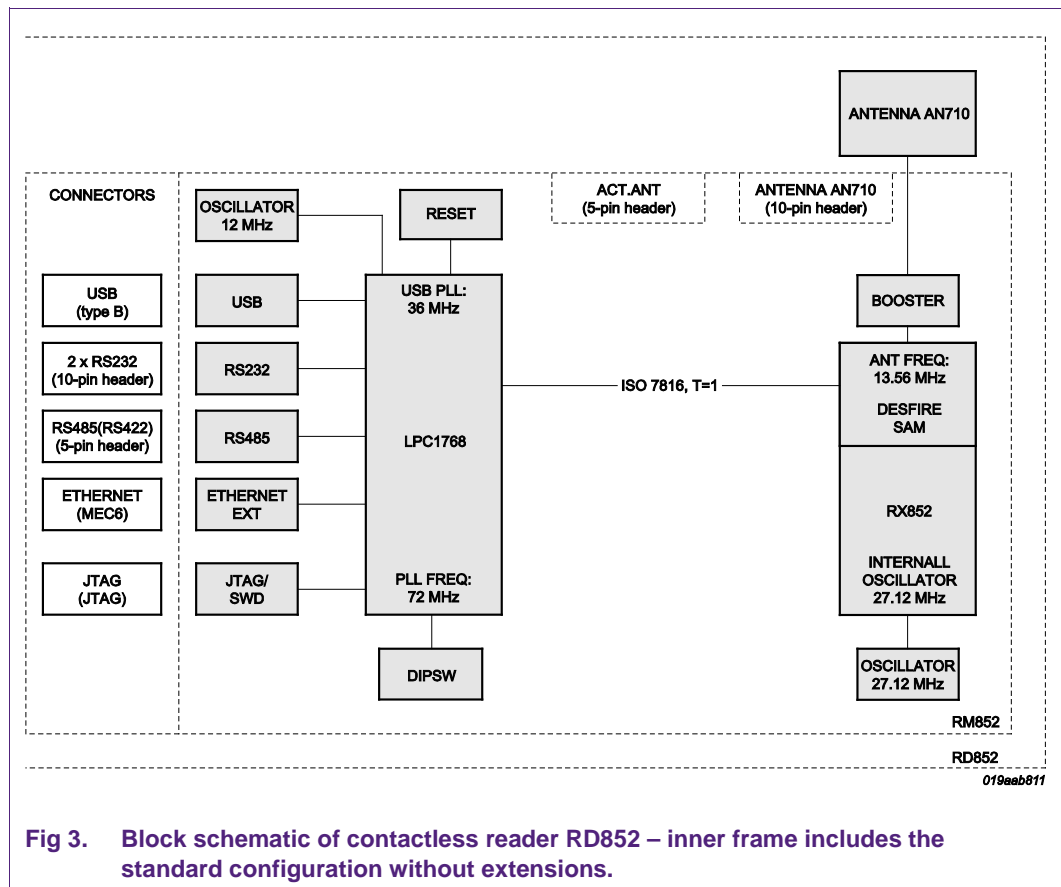

Fig 3. Block schematic of contactless reader RD852 – inner frame includes the standard configuration without extensions.

The microcontroller directly interfaces with its integrated peripherals to the host PC via serial port, USB or Ethernet. JTAG is only used for downloading firmware and debugging. The reader IC MFRX852 is connected directly via ISO7816 interface with the T=1 protocol implemented in SW on the  $\mu$ C. A SAM is integrated into MFRX852 device and used in X-configuration.

An additional amplifier enhances the RF output power to achieve higher field strengths. The amplifier is supplied by 5 Volts via USB bus power; the MFRX852 itself is only capable of handling a 3.3 Volts supply which is directly generated onboard from 5 Volts USB bus power.

The RD852 reader is designed to use an existing Pegoda RD701 housing with the AN710 antenna. The AN710 antenna is connected via 10-pin header to the RD852 board.

### 3.2.1 SAM RD852

The SAM is integrated in the MFRX852 reader IC module in X-configuration. Therefore the SIM socket for an additional SAM is not assembled.

### 3.2.2 Reader IC RD852

The RD852 contact less reader is equipped with a NXP IC MFRX852.

### 3.3 Hardware description RD710 and RD852

This section briefly describes the hardware implementation and features common to both readers; the RD710 and the RD852

#### 3.3.1 Interfaces

Interfaces included on RD710/RD852 board are: USB, RS232, RS485 (half or full duplex), Ethernet (via LPC\_COM extension board) and JTAG (via JTAG adapter).

The PCB RM710 and the PCB RM852 use the same connectors for applying the supply power and to access the communication interfaces and external antenna AN710. The only exception is SIM connector which is only present on the RM710 PCB.

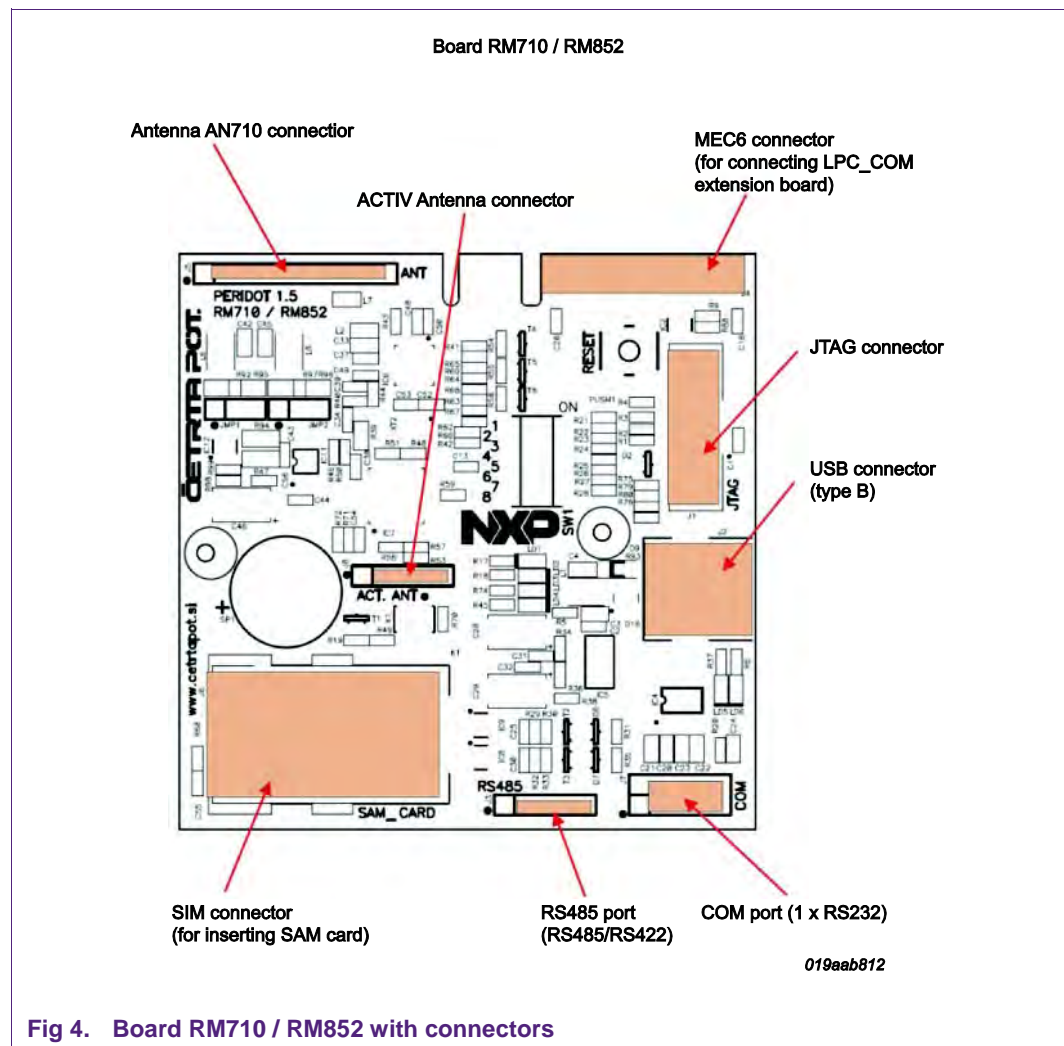

Fig 4. Board RM710 / RM852 with connectors

3.3.1.1 USB 2.0 Serial Port

The USB port is the default interface and always present on the RD710/RD852 board. The supported standard is USB 2.0 (full speed; 12 Mbit).

The PC delivers a power supply voltage of 5V DC (max. 500mA) for the RD710 or RD852 readers (boards RM710 / RM852) via USB interface. A secondary boot loader in the firmware enables the readers USB port for an easy firmware update.

USB connection and power supply filtering are given in Fig 5. The power supply of 5V DC is filtered via inductance L1. A protection is implemented via diode D9. If an external power of 5V DC on the 10-pin header is present, diode D9 prevents the USB bus to be supplied out of the reader device.

The IP4220CZ6 is incorporated to protect the USB 2.0 port (communication lines D- and D+) from ESD.

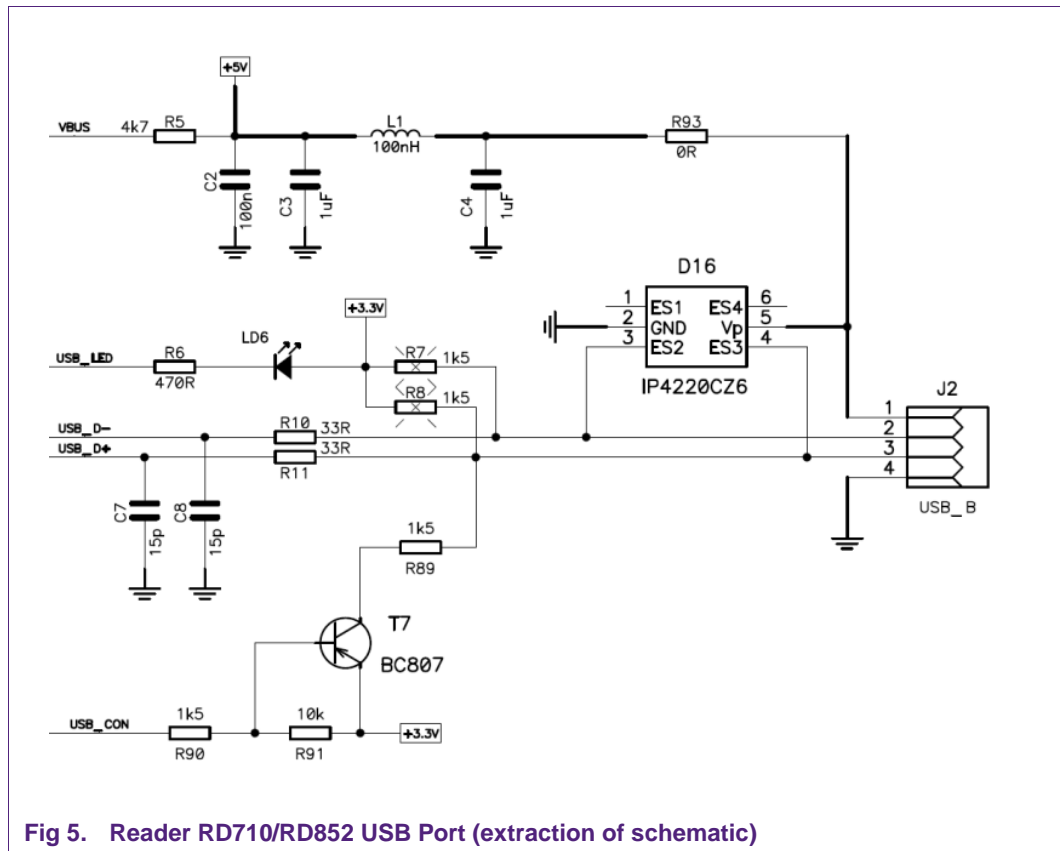

Fig 5. Reader RD710/RD852 USB Port (extraction of schematic)

Table 2. USB connector

Pin No.	Assign.	Description
1	+5V	Power +5V DC
2	D-	Communication line D-
3	D+	Communication line D+

Pin No.	Assign.	Description
4	GND	Ground

3.3.1.2 Two Serial Ports

One RS232 serial communication ports is wired out onto the 10-pin header COM; the second serial port is brought out to the MEC6 connector. The supported communication baud rates are: up to 115 200 bps.

The COM connector (10-pin header) is intended for serial communication with external devices via RS232 interface. One RS232 serial ports (with all handshake and control signals) is available on the 10-pin header. The +5V Power supply is also present on the 10-pin header to be able to supply reader RD710/RD852 without an USB connection (use as power supply input) or to supply an external device with 5 Volts (use as power supply output - max. current 200mA\* due to USB power specification).

The second serial port is connected to the MEC6 port (only the signals RxD, TxD and GND).

The primary boot loader uses the RS232 COM port for ISP programming in conjunction with an external downloading program on the PC (NXP recommends Flash Magic).

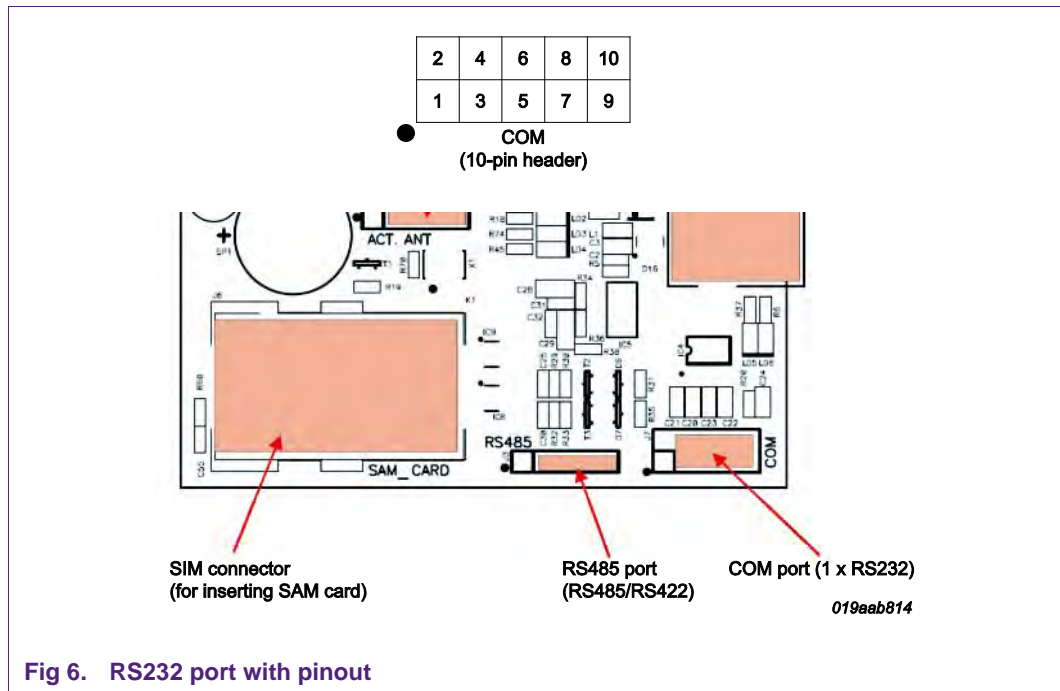

Fig 6. RS232 port with pinout

Table 3. COM connector (10-pin header)

Pin No.	Assign.	Description
1	DCD (/NMI)	Ext. /NMI signal (+12V)
2	RX	Receive
3	TX	Transmit
4	/	NC

Pin No.	Assign.	Description
5	GND	Ground
6	DSR (/MRST)	Ext. /Reset signal (+12V)
7	RTS	RTS signal
8	CTS	CTS signal
9	/	NC
10	+5V	Power +5V DC

One SP3232 level driver IC is used for converting the serial communication port to RS232 compatible signal levels including handshake control lines: RxD, TxD, RTS, CTS.

The DCD line is used as an external /NMI signal for the boot loader; the DSR line is used as an external /Reset (/MRST) signal. These two signals are used to set the reader RD710/RD852 into the boot loading mode (ISP).

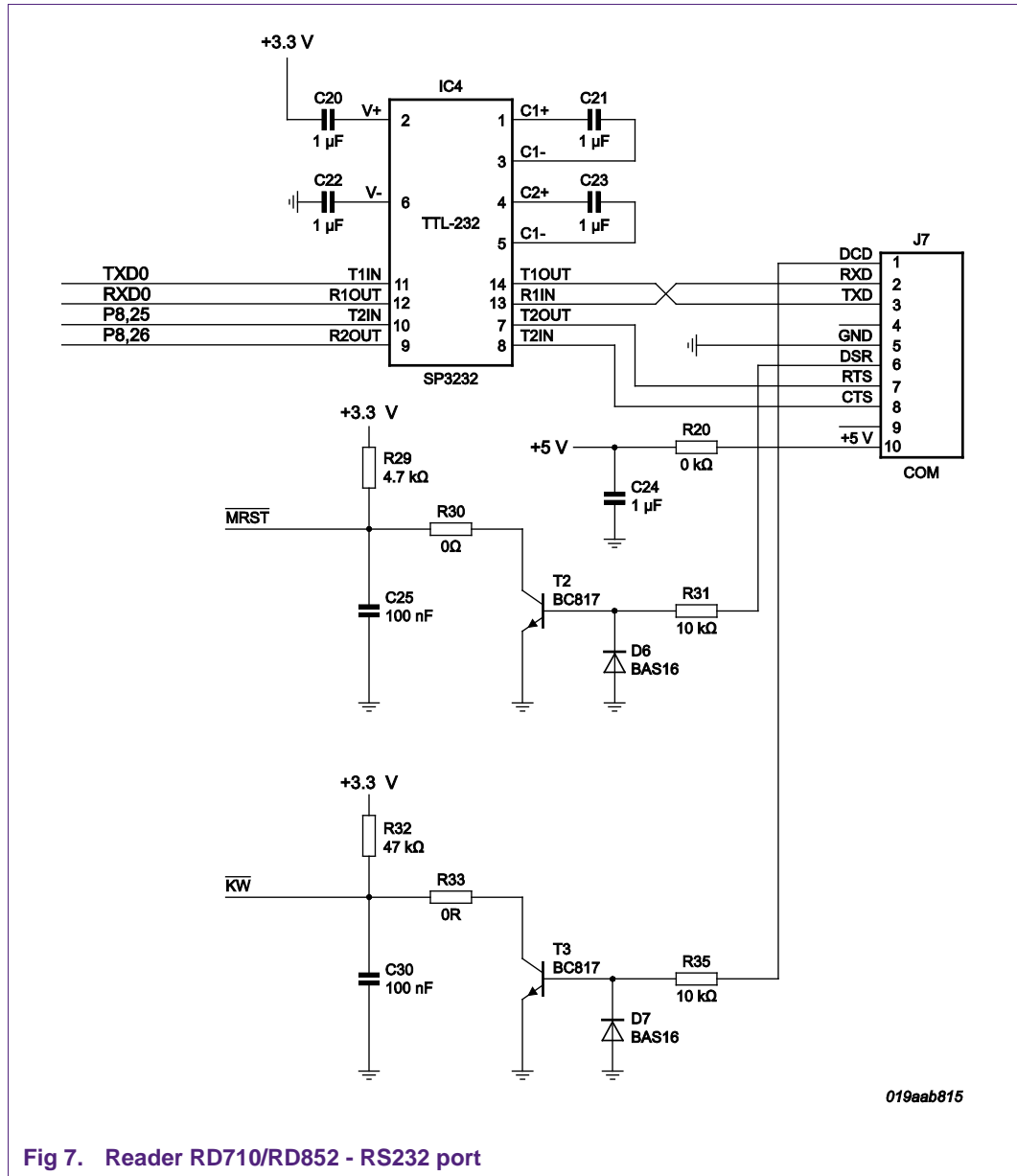

Fig 7. Reader RD710/RD852 - RS232 port

The second serial port is present on MEC6 connector. For this port no additional level drivers or protective elements are included. It is just wired out to the MEC6 from the microcontroller to provide the functionality.

### 3.3.1.3 One RS485 (half or full duplex) Serial Port

One RS485 serial communication port is also realized on the RD710/RD852 board. The supported communication speeds are up to 115 200 bps. The RS485 communication port is configurable as an RS485 half duplex or an RS485 full duplex port.

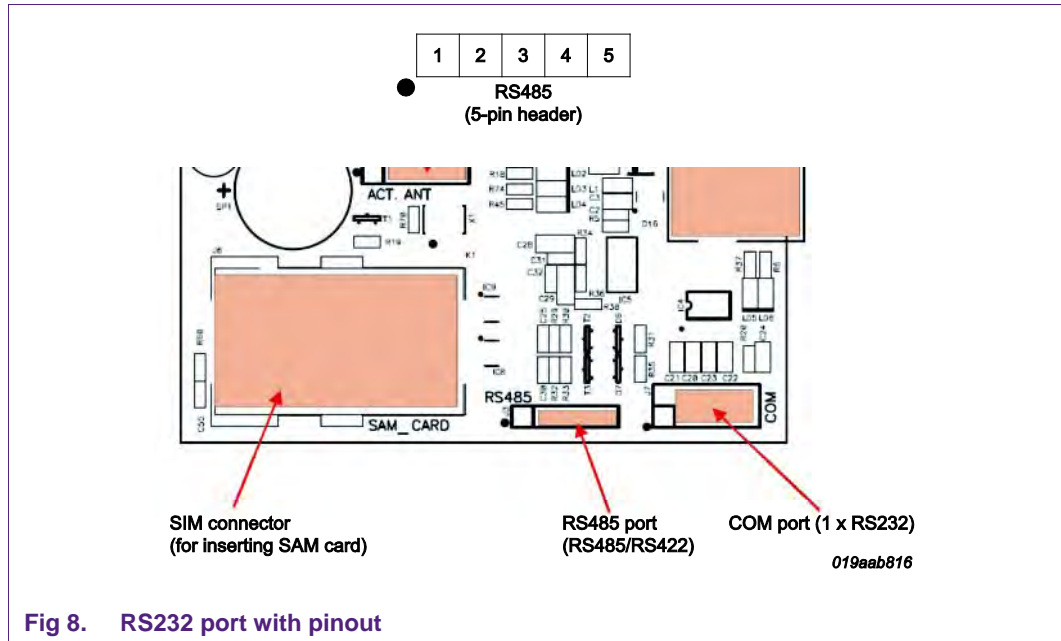

Fig 8. RS232 port with pinout

Table 4. RS485 connector (5-pin header)

Pin No.	Assign.	Description
1	TRP	Transmit/Receive P (RS485)
2	TRN	Transmit/Receive N (RS485)
3	GND	Ground
4	TP	Transmit P
5	TN	Transmit N

Using one RS485 driver as differential 2-wire communication in Half Duplex mode:

- Lines TRP and TRN are used for transmitting and receiving.

Using two RS485 drivers as 4-wire communication in Full Duplex mode:

- Lines TP and TN are used for transmitting; the TRP and TRN lines are used as receive path.



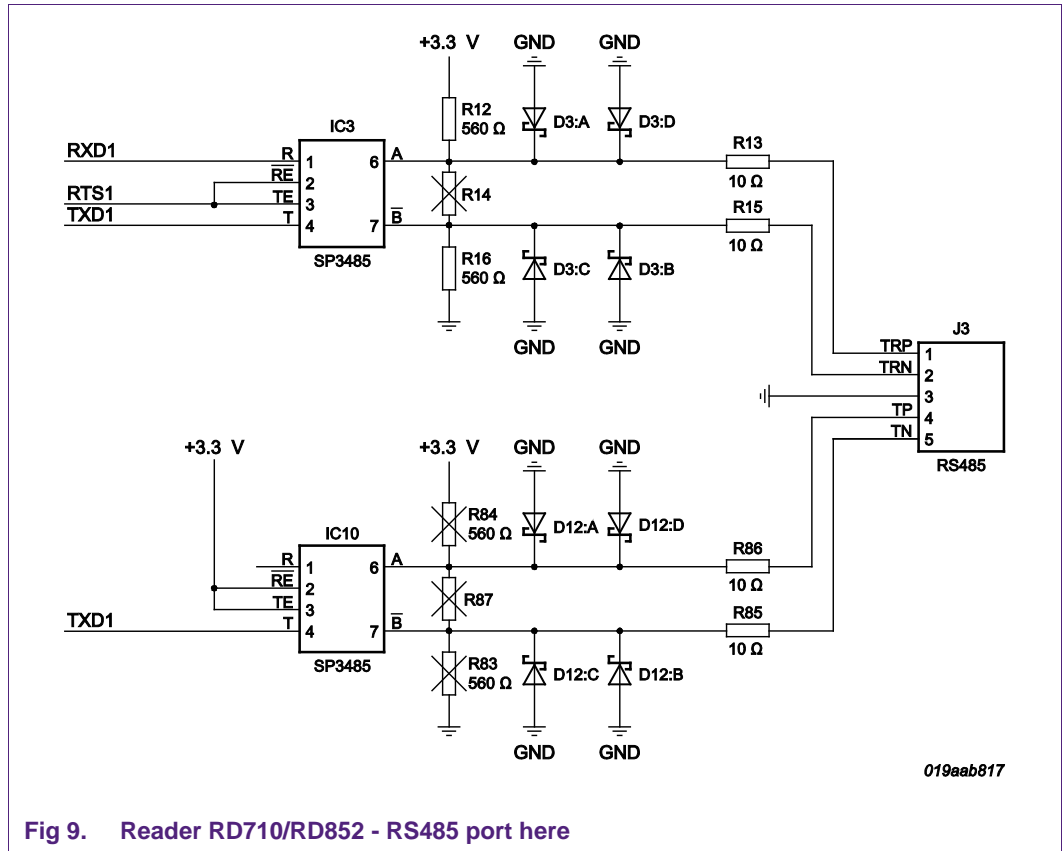

Fig 9. Reader RD710/RD852 - RS485 port here

### 3.3.1.4 IEEE802.3 Ethernet Port

The RD710/RD852 reader provides also an Ethernet port on the MEC6 connector. The physical Ethernet connection can be established over an additional HITEX LPC\_COM extension board.

The MEC6 connector is intended to be used in conjunction with the additional extension board which adds Ethernet connectivity for networking applications. Figures 10 and 11 are showing the MEC6 connector, Table 5 lists all signals.

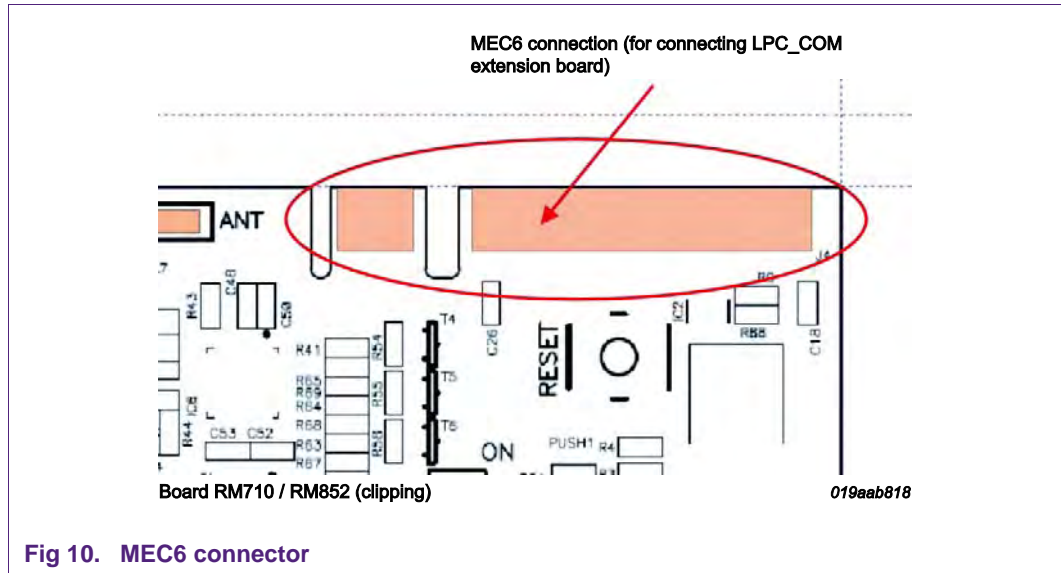

Fig 10. MEC6 connector

Table 5. MEC6 connector 80 (+20) - pin connector

Pin No.	Assign.	Description
1	VCC	Power (+3.3V)
2	VCC	Power (+3.3V)
3	/RST	/RST
10	GND	GND
12	P0.21	P0.21
21	GND	GND
22	GND	GND
24	TxD3	Transmit (COM3)
26	RxD3	Receive (COM3)
28	P2.12	P2.12
30	P2.13	P2.13
33	GND	GND
36	P1.22	P1.22
38	P1.22	P1.22
40	P1.29	P1.29
42	P1.31	P1.31
44	GND	GND
46	LED_4	LED_4
48	LED_3	LED_3
49	ENET_CRS	ENET_CRS
50	LED_2	LED_2
51	ENET_RXD1	ETHERNET RXD1
52	USB_CON	USB_CON
53	GND	GND

Pin No.	Assign.	Description
54	GND	GND
55	ENET_MDC	ETHERNET MDC
63	ENET_MDIO	ETHERNET MDIO
65	ENET_REF_CLK	ETHERNET REF_CLK
67	ENET_RX_ER	ETHERNET RX_ER
69	ENET_RXD0	ETHERNET RXD0
70	P2.3	P2.3
71	ENET_TXD1	ETHERNET TXD1
73	ENET_TX_EN	ETHERNET TX_EN
75	ENET_TXD0	ETHERNET TXD0
76	GND	GND
79	+5V	Power (+5V)
80	+5V	Power (+5V)
93	GND	GND
94	GND	GND
99	GND	GND
100	GND	GND

On MEC6 connector are signals for:

- Ethernet connection via LPT\_COM additional board,
- Additional serial port (COM2),
- Signals for driving LEDs,
- Power signals (+5V, +3.3V and GND),
- General purpose IO lines from the LPC1768 microcontroller.

### 3.3.1.5 JTAG IEEE1149.1 Port

The RD710/RD852 reader has a JTAG IEEE1149.1 debugging possibility via the JTAG connector. The LPC168 JTAG port is wired directly to the JTAG connector.

**Table 6. JTAG IEEE1149.1 interface 10-pin connector signals**

Pin No.	Assign.	Description
1	VCC	Power (+3.3V)
2	TMS	Test Mode State pin
3	GND	GND pin
4	TCLK	Test Clock pin
5	GND	GND pin
6	TDO	Test Data Out pin
7	RTCK	JTAG Return Test Clock pin

Pin No.	Assign.	Description
8	TDI	Test Data In
9	GND	GND pin
10	RST	Reset (active low)

3.3.2 DIP Switches

Both readers are sharing the same DIP switch configuration for setting some reader parameter like LEDs connection, RESET key and beeper driving.

Eight DIP switches are used to set different configurations for reader RD710 or RD852 (like reader operation mode, SAM mode, different communication modes). The function of the dedicated DIP switch is determined within the firmware which is programmed into the microcontroller’s flash memory. All DIP switch functions for the default software, which is originally delivered with the reader device, are described in detail in the SW design report. The ON/OFF position of DIP switches is shown in Table 7.

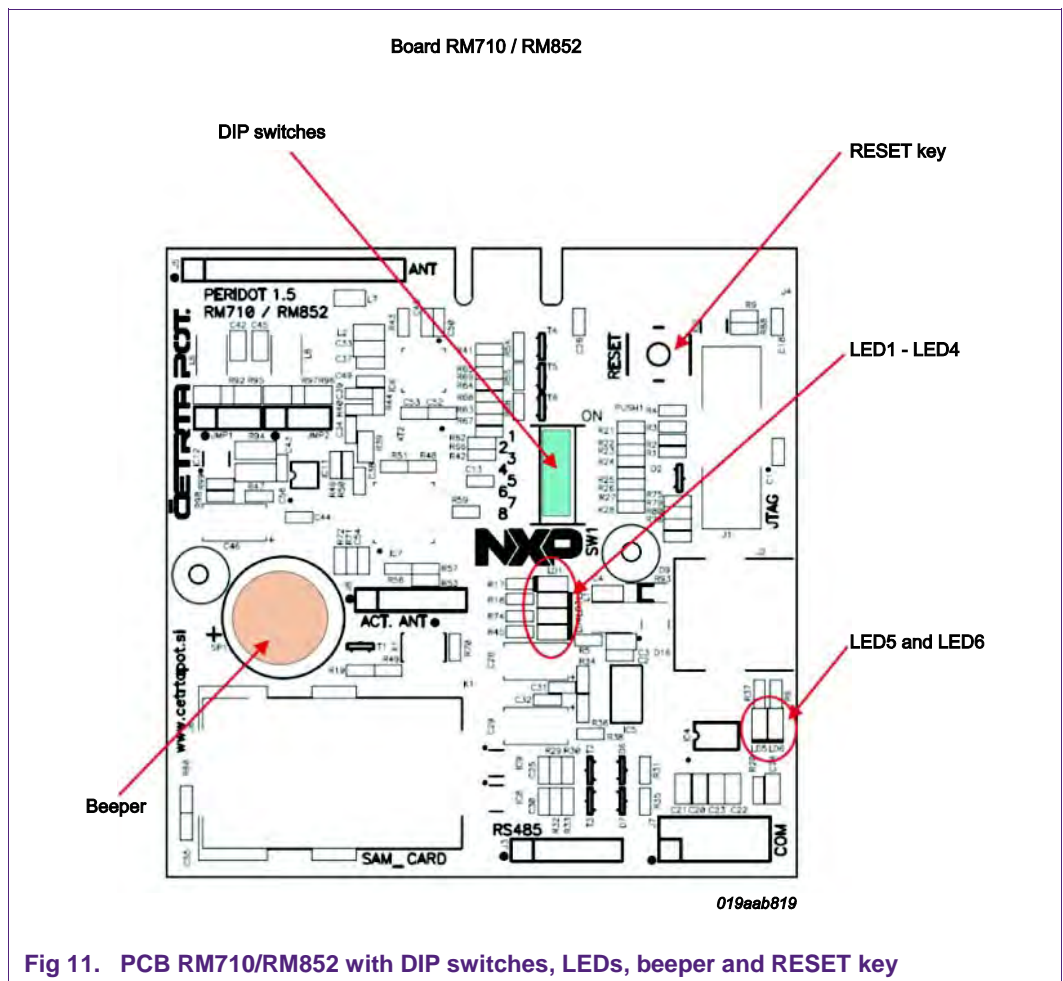

Fig 11. PCB RM710/RM852 with DIP switches, LEDs, beeper and RESET key

There are eight DIP switches on the reader and their functionality is described in Table 7.

Table 7. Reader configuration with DIP switches

DIP Switch Description								Description
8	7	6	5	4	3	2	1	
X	X	X	X	X	X	OFF	OFF	No SAM Reader (only RM710)
X	X	X	X	X	X	OFF	ON	SAM in non X-Mode (only RM710)
X	X	X	X	X	X	ON	OFF	SAM in X-Mode (only RM710)
X	X	X	X	X	X	ON	ON	RFU (RM710 – no, RM852 - no)
X	X	X	X	OFF	OFF	X	X	USB interface active (default)
X	X	X	X	OFF	ON	X	X	Serial (RS232) interface active
X	X	X	X	ON	OFF	X	X	Serial (RS485) interface active
X	X	X	X	ON	ON	X	X	Ethernet interface active
X	X	OFF	OFF	X	X	X	X	SPI interface (only RM710)
X	X	OFF	ON	X	X	X	X	I2C interface (only RM710)
X	X	ON	OFF	X	X	X	X	UART interface (only RM710)
X	X	ON	ON	X	X	X	X	RFU (RM710 – no, RM852 - no)
OFF	OFF	X	X	X	X	X	X	PC/SC reader mode
OFF	ON	X	X	X	X	X	X	Demo mode
ON	OFF	X	X	X	X	X	X	Overwrite user configuration with factory defaults
ON	ON	X	X	X	X	X	X	Enter secondary boot loader emergency flash mode

### 3.3.2.1 RESET Key

The RESET key is designed as hardware reset function - for resetting PCB RD710 / RD852 reader.

### 3.3.2.2 BEEPER (BUZZER)

The beeper is an acoustic signal to state out several conditions of the reader to demonstrate the card access and data transfer. Short and long whistles can be used to provide information like successful or unsuccessful card readings, device resets, device power status, error signaling and more.

### 3.3.2.3 LEDs

Both versions of the readers are equipped with the same number of LEDs: 6 luminescent components can be used to show different states or operating conditions. The function of the dedicated LED is described in Table 8; the position of LEDs is shown in Fig 11.

**Table 8. Function of the LEDs**

LED No.	LED color	Function
1	yellow	USB led (connect)
2	yellow	programmable
3	yellow	programmable
4	yellow	programmable
5	red	PWR (power supply)
6	green	USB led

3.3.3 RF Amplifier with 5 Volts Supply

The RF booster amplifier circuit is similar for both reader ICs – for MFRC523 and the MFRX852. Due to 3.3 V TVDD supply limitation on the reader ICs two high speed MOSFET drivers are used for increasing the output power on the AN710 antenna. The RF amplifier is supplied from the 5 V USB bus power.

The antenna is matched in regard to output power and compliancy to ISO14443A limits for baud rates from 106 kbps to 848 kbps.

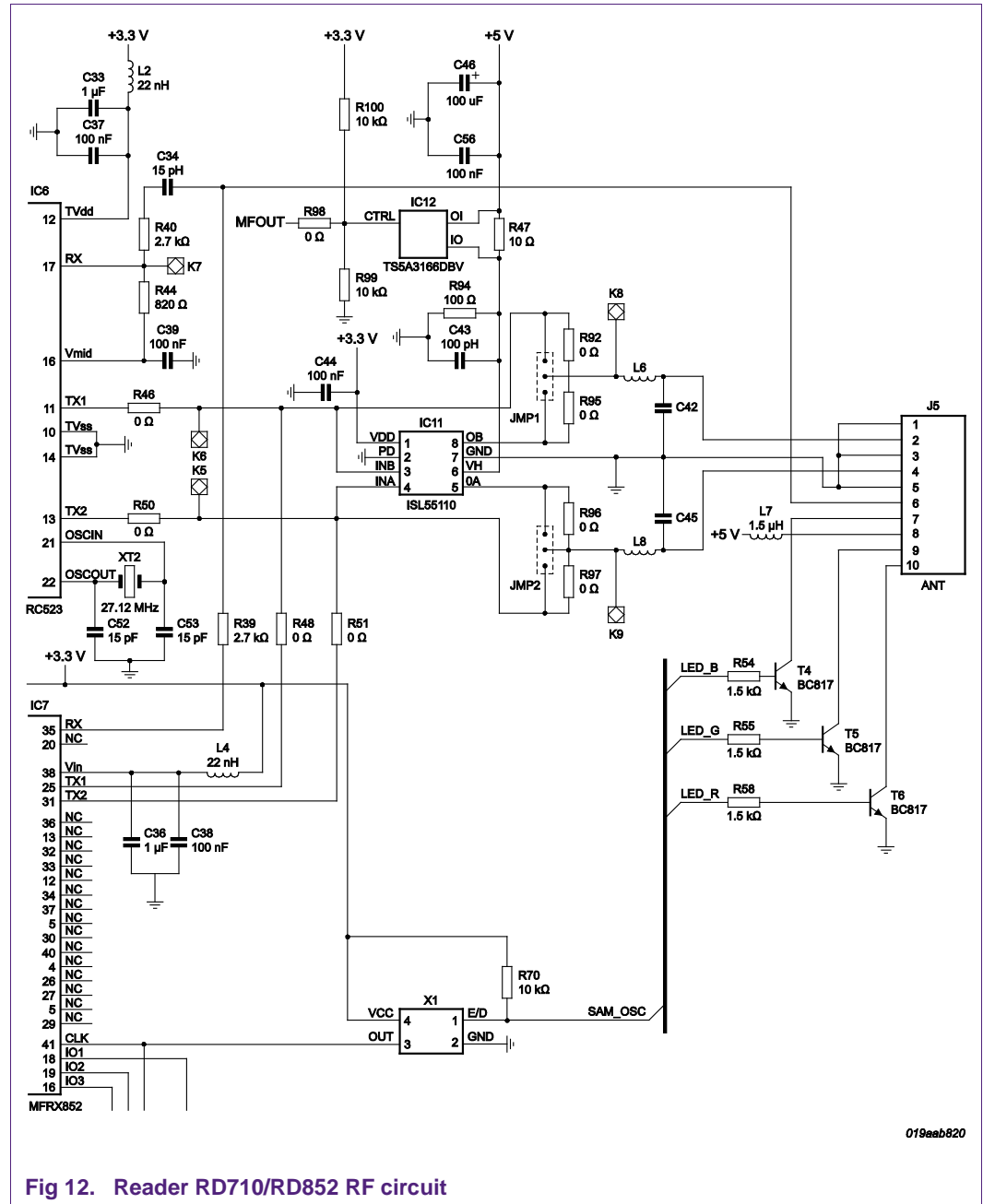

Fig 12. Reader RD710/RD852 RF circuit

3.3.3.1 5 Volts Power Supply

The RM710 and RM852 boards are using a 5 V DC external power supply. The default configuration is powering the device over the USB port. The additional possibility is applying a 5 V supply to the dedicated power pin at the 10-pin header (COM).

The 5 V DC supply voltage from the personal computers USB port is filtered via inductance L1.

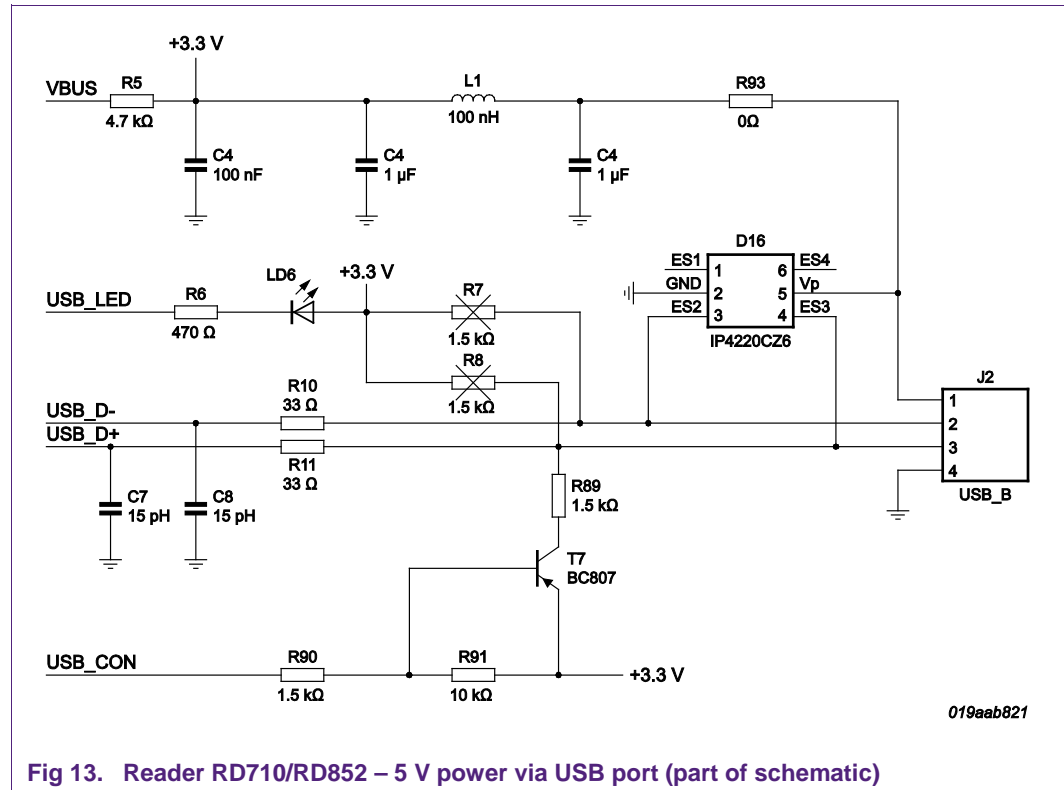

Fig 13. Reader RD710/RD852 – 5 V power via USB port (part of schematic)





3.3.3.2 Internal 3.3 V Power Supply

The internal 3.3 V power supply for the microcontroller, the reader ICs and some other components is derived from IC5, a LP3961-3.3 linear voltage regulator. All additional components for filtering and stabilizing the voltage regulator follow the recommendations described in the datasheet of the LP3961-3.3. The input voltage of 5 V DC is regulated down to a stabilized 3.3 V DC for supplying the reader IC and the microcontroller.

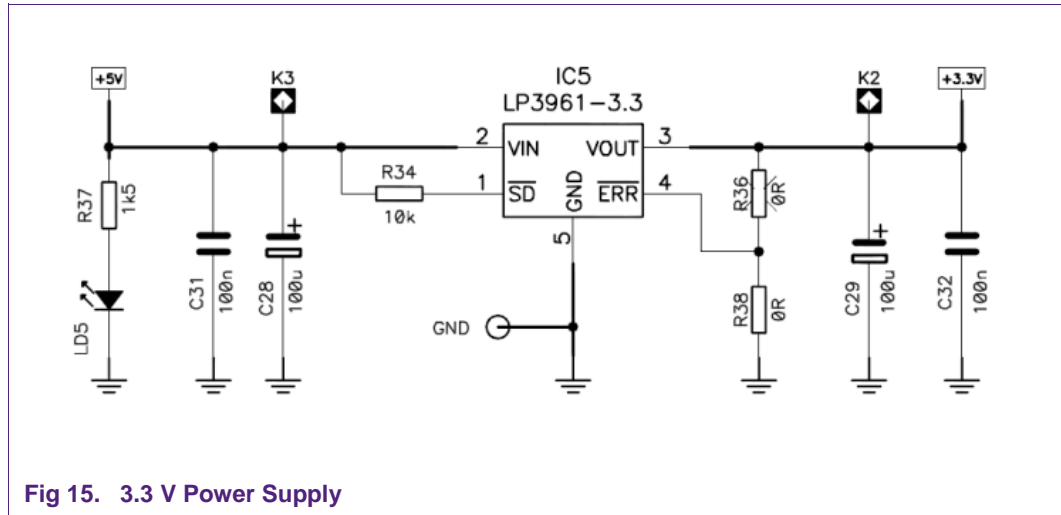

Fig 15. 3.3 V Power Supply

3.3.4 Reset Circuit

A reset switch (RESET) and External Reset line (/MRST) are attached to the same reset generator IC MAX811 for providing a proper reset signal as described in the LPC1768 datasheet.

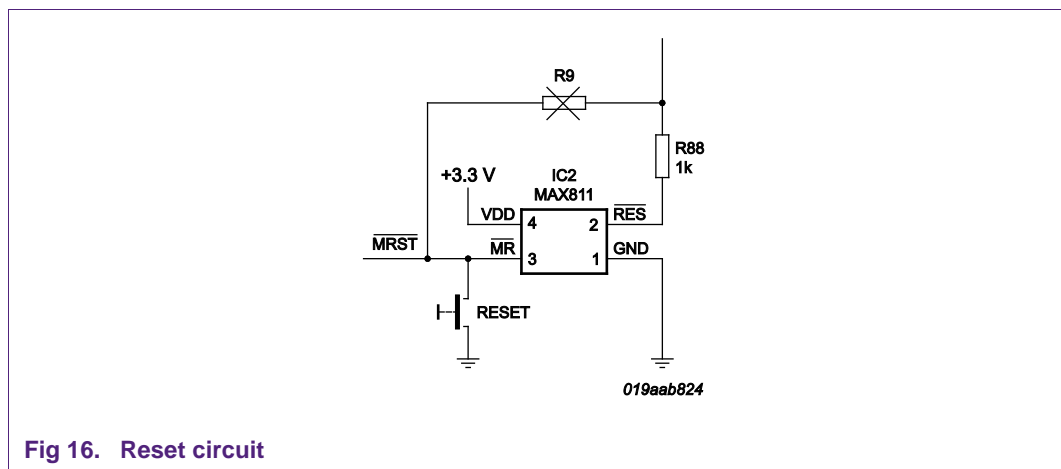

Fig 16. Reset circuit

3.3.5 Antenna AN710

The AN710 antenna has the same form factor as the antenna used in the existing AN700 Pegoda reader and it is directly connected to the 10-pin antenna header. The antenna in combination with the main board (RM710, RM852) builds up the complete matching circuit and is tuned for optimum performance.

**Note that part of the matching components is placed on the antenna. Exchanging antennas AN710 with AN700 (antenna of previous Pegoda) will result in antenna mismatch and reduced reading performance.**

An additional connector for attaching an active antenna to the RD710/RD852 reader is provided (5-pin header active antenna) on the PCB to be able to easily implement different reader architectures. In this case the modulation input and output of the reader IC MFRC523 and MFRX852 are accessible at this pin header.

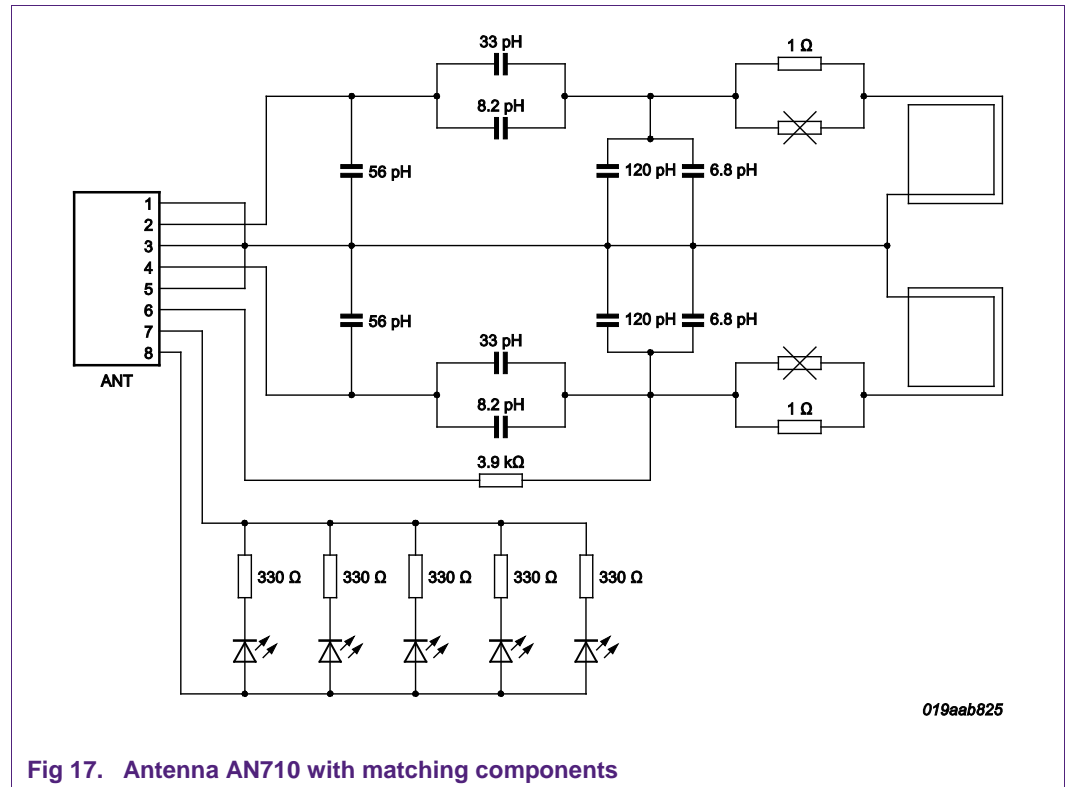

3.3.6 Mechanical Requirements

The PCB boards RM710 and RM852 fit into the current RD701 Pegoda housing. Therefore the maximum outer dimension of the PCB board is limited to 72 x 72 mm.

The RM710 and RM852 boards include an extension connector MEC6 for the HITEX LPC-COM board at the same mechanical position. Additionally all other mechanical requirements for a reuse of the RD 701 housing are considered. These requirements are:

- The positions of the USB connector
- The position of the mounting screws
- The position of the antenna connection
- Height of components on the PCB

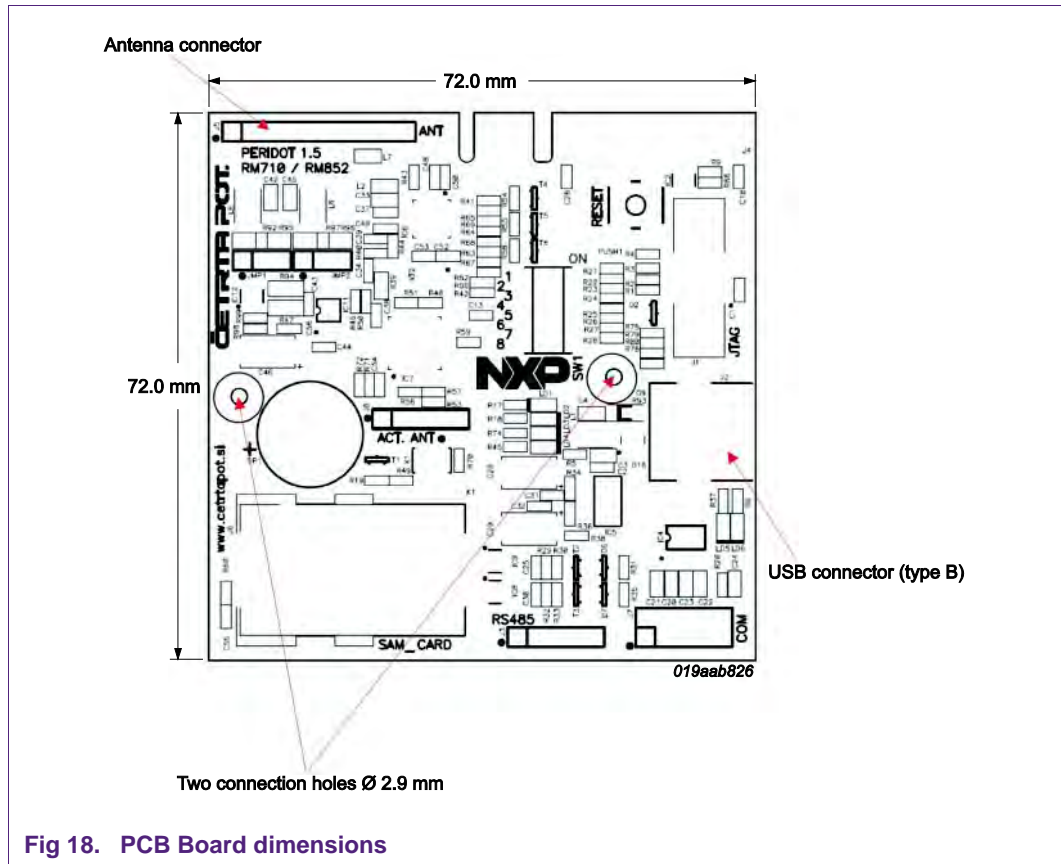

Fig 18. PCB Board dimensions

### 3.3.7 Electrical Requirements

The board is USB bus powered. This requires a limitation of the maximum power consumption below of 2.5 Watts at rated 5 volts supply, which corresponds to a maximum of 500 mA supply current over the USB connection. The reader is designed to work in a range of 4.75 to 5.25 Volts and to stay fully functional within this range. The typical power consumption (without an additional LPC\_COM board) is 170 mA.

### 3.3.8 Electrical characteristics

#### Operating Range

Symbol	Description	Conditions	Min	Typ	Max	Unit
+5V	+5V Power Supply	Active Reader	4.75	5.00	5.25	V
T <sub>amb</sub>	Ambient Temperature	/	-25	+25	+85	°C

#### Current Consumption

Symbol	Description	Conditions	Min	Typ	Max	Unit
IC5V	Supply Current	Active, RF on	-	170	-	mA

#### Operating Distance

Symbol	Description	Conditions	Min	Typ	Max	Unit
DST	Operating Distance	Measured from the center of the antenna	-	0 – 75	-	mm

#### Interface Characteristics

Symbol	Description	Conditions	Min	Typ	Max	Unit
USB	USB Baudrate	Cable length max. 1 m	-	12	-	Mbaud
RS232	RS232 baud rate	Cable length max. 1 m	-	115 200	-	bps
RS485	RS485 baud rate	Cable length max. 1 m	-	115 200	-	bps

### 3.4 Overall Hardware RD710/RD852 Specifications

#### Contactless reader RD710 specifications

Antenna	
External Antenna	Model AN710 (for both readers)
Additional antenna output	5-pin header: for active antenna
Contactless operating frequency	
13.56 MHz	
Contactless (RFID) Smart Card Interface	
ISO 14443 A with 848 Kbps transmission rate (depending on card)	
ISO 14443 B with 848 Kbps transmission rate (depending on card), not implemented	
MIFARE SAM Interface (for RD710 reader)	
Standards	ISO/IEC 7816
Protocols	T=1
Baud rate	9.6 to 1500 Kbps
Smart card clock frequency	Up to 10MHz
Connection	S- mode, X - mode
Host Interface	
Host Interface	USB 2.0 (also supported USB 1.1)
Transmission Speed	12 Mbps (USB 2.0 full speed)
Power Supply	Bus powered
Other Communication Interfaces	
RS 232C Serial Interface	1 serial ports; connector type: 10-pin Header; Communication speed: 115 200 bps (standard)
RS 485 Serial Interface	1 serial ports; configurable as RS485 (half or full duplex), connector type: 5-pin Header; Communication speed: 115 200 bps (standard)
JTAG IEEE1149.1 Serial Interface	JTAG 10-pin connector; to connect JTAG adapter
IEEE802.3 Ethernet Interface	Supported via LPC-COM extension board on MEC6 connector; connector type MEC6
Electrical and Mechanical Specifications	
Power Supply	5V DC $\pm$ 5%, 290 mA (via USB port or via 10-pin Header)
Dimensions (L x W x H)	72 mm x 72 mm x 16 mm (passed in Pegoda housing)
Weight	approx. 33g (reader RD710)
Operating Temperature	-25 ... + 85 °C (without condensing)
Operating Humidity	5 ... 95% RH

## Contactless reader RD852 specifications

Antenna	
External Antenna	Model AN710 (for both readers)
Additional antenna output	5-pin header: for active antenna
Contactless operating frequency	
13.56 MHz	
Contactless (RFID) Smart Card Interface	
ISO 14443 A with 848 Kbps transmission rate (depending on card)	
ISO 14443 B with 848 Kbps transmission rate (depending on card) , not implemented	
MIFARE SAM Interface (for RD852 reader)	
Standards	ISO/IEC 7816, T=1
SAM in X - mode	SAM in X-mode incorporated in MFRX852 IC
Host Interface	
Host Interface	USB 2.0 (also supported USB 1.1)
Transmission Speed	12 Mbps (USB 2.0 full speed)
Power Supply	Bus powered
Other Communication Interfaces	
RS 232C Serial Interface	1 serial ports; connector type: 10-pin Header; Communication speed: 115 200 bps (standard)
RS 485 Serial Interface	1 serial ports; configurable as RS485 (half or full duplex), connector type: 5-pin Header; Communication speed: 115 200 bps (standard)
JTAG IEEE1149.1 Serial Interface	JTAG 10-pin connector; to connect JTAG adapter
IEEE802.3 Ethernet Interface	Supported via LPC-COM extension board on MEC6 connector; connector type MEC6
Electrical and Mechanical Specifications	
Power Supply	5V DC $\pm$ 5%, 290 mA (via USB port or via 10-pin Header)
Dimensions (L x W x H)	72 mm x 72 mm x 16 mm (fitting into RD700 Pegoda housing)
Weight	approx. 32g (reader RD852)
Operating Temperature	-25 ... + 85 °C (non condensating)
Operating Humidity	5 ... 95% RH

## 3.5 RD710/RD852 schematics

The schematics can be found on the CD.

## 4. Legal information

### 4.1 Definitions

**Draft** — The document is a draft version only. The content is still under internal review and subject to formal approval, which may result in modifications or additions. NXP Semiconductors does not give any representations or warranties as to the accuracy or completeness of information included herein and shall have no liability for the consequences of use of such information.

### 4.2 Disclaimers

**Limited warranty and liability** — Information in this document is believed to be accurate and reliable. However, NXP Semiconductors does not give any representations or warranties, expressed or implied, as to the accuracy or completeness of such information and shall have no liability for the consequences of use of such information.

In no event shall NXP Semiconductors be liable for any indirect, incidental, punitive, special or consequential damages (including - without limitation - lost profits, lost savings, business interruption, costs related to the removal or replacement of any products or rework charges) whether or not such damages are based on tort (including negligence), warranty, breach of contract or any other legal theory.

Notwithstanding any damages that customer might incur for any reason whatsoever, NXP Semiconductors' aggregate and cumulative liability towards customer for the products described herein shall be limited in accordance with the Terms and conditions of commercial sale of NXP Semiconductors.

**Right to make changes** — NXP Semiconductors reserves the right to make changes to information published in this document, including without limitation specifications and product descriptions, at any time and without notice. This document supersedes and replaces all information supplied prior to the publication hereof.

**Suitability for use** — NXP Semiconductors products are not designed, authorized or warranted to be suitable for use in life support, life-critical or safety-critical systems or equipment, nor in applications where failure or malfunction of an NXP Semiconductors product can reasonably be expected to result in personal injury, death or severe property or environmental damage. NXP Semiconductors accepts no liability for inclusion and/or use of NXP Semiconductors products in such equipment or applications and therefore such inclusion and/or use is at the customer's own risk.

**Applications** — Applications that are described herein for any of these products are for illustrative purposes only. NXP Semiconductors makes no representation or warranty that such applications will be suitable for the specified use without further testing or modification.

Customers are responsible for the design and operation of their applications and products using NXP Semiconductors products, and NXP Semiconductors accepts no liability for any assistance with applications or customer product design. It is customer's sole responsibility to determine whether the NXP Semiconductors product is suitable and fit for the customer's applications and products planned, as well as for the planned application and use of customer's third party customer(s). Customers should provide appropriate design and operating safeguards to minimize the risks associated with their applications and products.

NXP Semiconductors does not accept any liability related to any default, damage, costs or problem which is based on any weakness or default in the customer's applications or products, or the application or use by customer's third party customer(s). Customer is responsible for doing all necessary testing for the customer's applications and products using NXP

Semiconductors products in order to avoid a default of the applications and the products or of the application or use by customer's third party customer(s). NXP does not accept any liability in this respect.

**Export control** — This document as well as the item(s) described herein may be subject to export control regulations. Export might require a prior authorization from national authorities.

**Evaluation products** — This product is provided on an "as is" and "with all faults" basis for evaluation purposes only. NXP Semiconductors, its affiliates and their suppliers expressly disclaim all warranties, whether express, implied or statutory, including but not limited to the implied warranties of non-infringement, merchantability and fitness for a particular purpose. The entire risk as to the quality, or arising out of the use or performance, of this product remains with customer.

In no event shall NXP Semiconductors, its affiliates or their suppliers be liable to customer for any special, indirect, consequential, punitive or incidental damages (including without limitation damages for loss of business, business interruption, loss of use, loss of data or information, and the like) arising out the use of or inability to use the product, whether or not based on tort (including negligence), strict liability, breach of contract, breach of warranty or any other theory, even if advised of the possibility of such damages.

Notwithstanding any damages that customer might incur for any reason whatsoever (including without limitation, all damages referenced above and all direct or general damages), the entire liability of NXP Semiconductors, its affiliates and their suppliers and customer's exclusive remedy for all of the foregoing shall be limited to actual damages incurred by customer based on reasonable reliance up to the greater of the amount actually paid by customer for the product or five dollars (US\$5.00). The foregoing limitations, exclusions and disclaimers shall apply to the maximum extent permitted by applicable law, even if any remedy fails of its essential purpose.

### 4.3 Licenses

#### Purchase of NXP ICs with ISO/IEC 14443 type B functionality



This NXP Semiconductors IC is ISO/IEC 14443 Type B software enabled and is licensed under Innovatron's Contactless Card patents license for ISO/IEC 14443 B.

The license includes the right to use the IC in systems and/or end-user equipment.

RATP/Innovatron  
Technology

### 4.4 Trademarks

Notice: All referenced brands, product names, service names and trademarks are property of their respective owners.

**MIFARE** — is a trademark of NXP B.V.



## 5. List of figures

Fig 1.	RD710 board.....	5
Fig 2.	Block schematic of contactless reader RD710 – inner frame includes the standard configuration without extensions. ....	8
Fig 3.	Block schematic of contactless reader RD852 – inner frame includes the standard configuration without extensions. ....	9
Fig 4.	Board RM710 / RM852 with connectors .....	11
Fig 5.	Reader RD710/RD852 USB Port (extraction of schematic).....	12
Fig 6.	RS232 port with pinout.....	13
Fig 7.	Reader RD710/RD852 - RS232 port.....	15
Fig 8.	RS232 port with pinout.....	16
Fig 9.	Reader RD710/RD852 - RS485 port here .....	17
Fig 10.	MEC6 connector .....	18
Fig 11.	PCB RM710/RM852 with DIP switches, LEDs, beeper and RESET key .....	20
Fig 12.	Reader RD710/RD852 RF circuit.....	23
Fig 13.	Reader RD710/RD852 – 5 V power via USB port (part of schematic) .....	24
Fig 14.	Reader RD710/RD852 – 5 V power via 10-pin header (part of schematic) .....	25
Fig 15.	3.3 V Power Supply .....	26
Fig 16.	Reset circuit .....	26
Fig 17.	Antenna AN710 with matching components ...	27
Fig 18.	PCB Board dimensions.....	28

## 6. List of tables

---

Table 1.	Numbering of Figure 1 .....	5
Table 2.	USB connector.....	12
Table 3.	COM connector (10-pin header) .....	13
Table 4.	RS485 connector (5-pin header).....	16
Table 5.	MEC6 connector 80 (+20) - pin connector .....	18
Table 6.	JTAG IEEE1149.1 interface 10-pin connector signals.....	19
Table 7.	Reader configuration with DIP switches.....	21
Table 8.	Function of the LEDs .....	22

## 7. Contents

<b>1.</b>	<b>General information .....</b>	<b>3</b>
1.1	Scope.....	3
1.2	General Description .....	3
1.3	Naming Convention.....	4
<b>2.</b>	<b>Understanding the parts of RD710 and RD852 .....</b>	<b>5</b>
2.1	RD710 Features.....	6
2.2	RD852 Features.....	7
<b>3.</b>	<b>RD710 / RD852 HARDWARE DESCRIPTION .....</b>	<b>8</b>
3.1	Overall Hardware RD710 .....	8
3.1.1	Plugging SAM RD710 .....	9
3.1.2	Reader IC RD710.....	9
3.2	Overall Hardware RD852 .....	9
3.2.1	SAM RD852 .....	10
3.2.2	Reader IC RD852.....	10
3.3	Hardware description RD710 and RD852 .....	11
3.3.1	Interfaces .....	11
3.3.1.1	USB 2.0 Serial Port .....	12
3.3.1.2	Two Serial Ports.....	13
3.3.1.3	One RS485 (half or full duplex) Serial Port .....	15
3.3.1.4	IEEE802.3 Ethernet Port.....	17
3.3.1.5	JTAG IEEE1149.1 Port .....	19
3.3.2	DIP Switches.....	20
3.3.2.1	RESET Key.....	21
3.3.2.2	BEEPER (BUZZER).....	21
3.3.2.3	LEDs .....	21
3.3.3	RF Amplifier with 5 Volts Supply .....	23
3.3.3.1	5 Volts Power Supply .....	24
3.3.3.2	Internal 3.3 V Power Supply.....	26
3.3.4	Reset Circuit.....	26
3.3.5	Antenna AN710.....	27
3.3.6	Mechanical Requirements.....	28
3.3.7	Electrical Requirements .....	29
3.3.8	Electrical characteristics.....	29
3.4	Overall Hardware RD710/RD852 Specifications .....	30
3.5	RD710/RD852 schematics .....	31
<b>4.</b>	<b>Legal information .....</b>	<b>32</b>
4.1	Definitions .....	32
4.2	Disclaimers.....	32
4.3	Licenses.....	32
4.4	Trademarks.....	32
<b>5.</b>	<b>List of figures.....</b>	<b>33</b>
<b>6.</b>	<b>List of tables .....</b>	<b>34</b>
<b>7.</b>	<b>Contents.....</b>	<b>35</b>

Please be aware that important notices concerning this document and the product(s) described herein, have been included in the section 'Legal information'.

© NXP B.V. 2011.

All rights reserved.

For more information, please visit: <http://www.nxp.com>  
For sales office addresses, please send an email to:  
[salesaddresses@nxp.com](mailto:salesaddresses@nxp.com)

Date of release: 6 June 2011  
191211

Document identifier: AN10991